

Overview



ST-H transducers use ultrasonic technology to measure level in chemical storage and liquid tanks.

Benefits

- Can be mounted on a narrow standpipe
- Immune to corrosive and harsh environments
- Integral temperature sensor

Application

The narrow design of the ST-H allows the transducer to be mounted on a narrow standpipe. When mounted correctly, it is completely protected from the process and can even be used in harsh, corrosive environments.

During operation, the ultrasonic transducer emits acoustic pulses in a narrow beam perpendicular to the transducer face. The level transceiver measures the propagation time between pulse emission and reception of the echo to calculate the distance from the transducer to the material. Variations in sound velocity due to changes in temperature within the permissible range are automatically compensated by the integral temperature sensor.

- Key Applications: chemical storage, liquid tanks

Technical specifications

Mode of operation	
Measuring principle	Ultrasonic transducer
Input	
Measuring range	0.3 ... 10 m (1 ... 33 ft)
Output	
Frequency	44 kHz
Beam angle	12°
Accuracy	
Temperature compensation	Compensated by integral temperature sensor
Rated operating conditions	
Pressure	Normal atmospheric pressure
Ambient conditions	
Ambient temperature	-20 ... +60 °C (-5 ... +140 °F) (ATEX approved model) -40 ... +73 °C (-40 ... +163 °F) (CSA/FM approved model)
Storage temperature	-20 ... +60 °C (-5 ... +140 °F)
Design	
Weight ¹⁾	1.4 kg (3 lb)
Material (enclosure)	Base and lid made of ETFE or PVDF (epoxy fitted joint) ²⁾
Process connection	2" NPT [(Taper), ANSI/ASME B1.20.1], R 2" [(BSPT), EN 10226] or G 2" [(BSPP), EN ISO 228-1]
Degree of protection	IP68
Cable connection	2-core shielded/twisted, 0.519 mm ² (20 AWG), PVC sheath
Cable (max. length)	365 m (1 200 ft) with RG 62 A/U coaxial cable
Options	
Flange adapter	3" Universal (fits DN 65, PN 10 and 3" ASME)
Certificates and approvals	
CE, CSA Class I, II, III, Div. 1, Groups A, B, C, D, E, F, G T3 (ETFE only), FM Class I, II, Div. 1, Groups C, D, E, F, G T4A, ATEX II 2G / INMETRO Ex mb IIC T5 Gb, RCM, KCC	

¹⁾ Approximate shipping weight of transducer with standard cable length

²⁾ When measuring chemicals, check compatibility of ETFE or PVDF and epoxy, or mount joint external to process.

Dimensional drawings

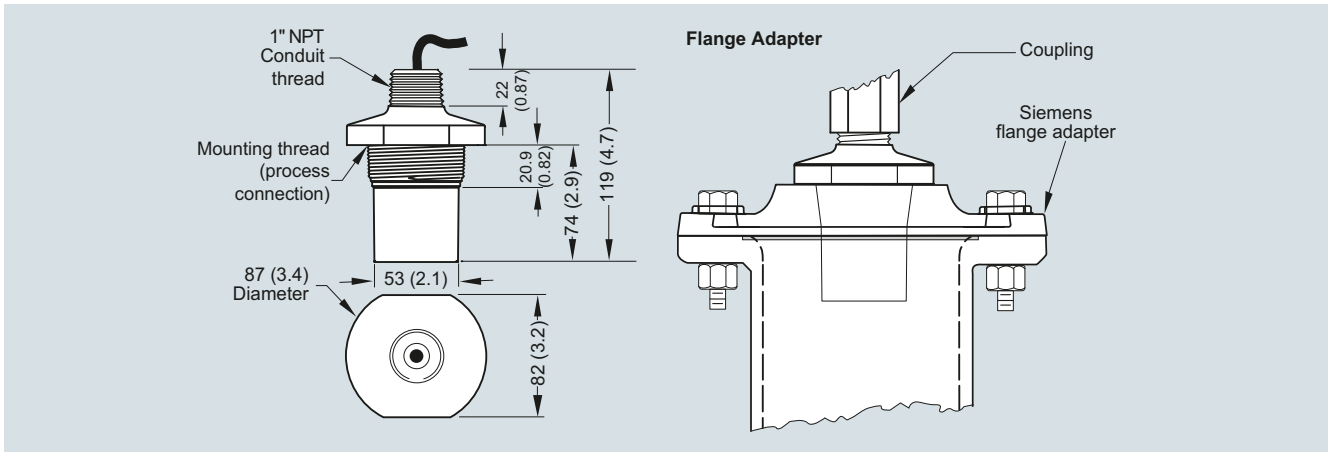

ST-H ultrasonic transducer, dimensions in mm (inch)

Circuit diagrams

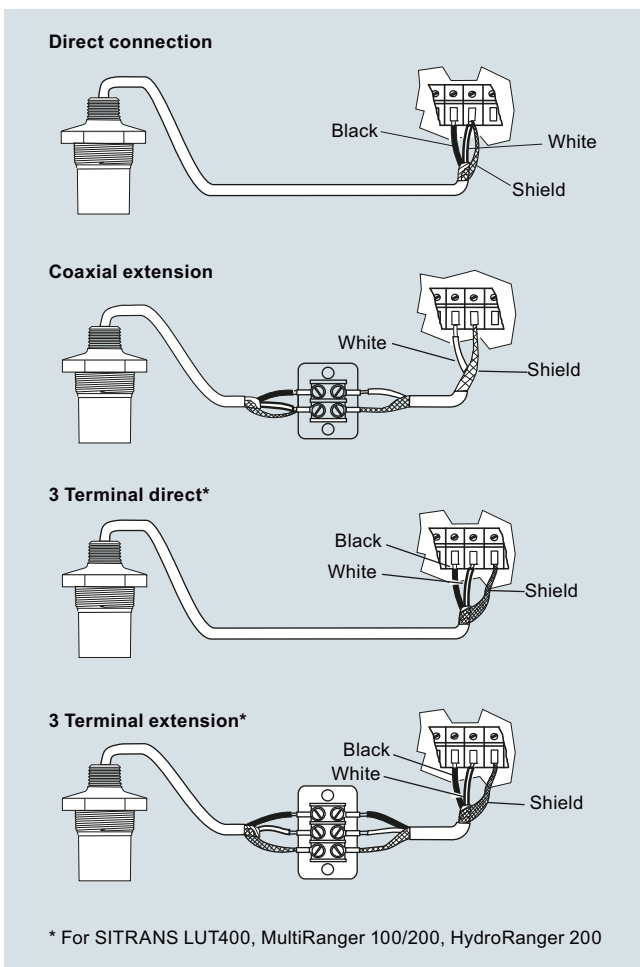

ST-H ultrasonic transducer connections